

Model 302

Back Pressure Check Valve



**METAL GOODS
MANUFACTURING**

428 W. 8th Street | Bartlesville, OK 74003

1-800-628-4282 (ph.) | 1-918-336-3993 (fax)

www.metalgoods.com | support@metalgoods.com



WARNING

Please read this manual carefully before installing and operating the valves:

1. The valves are only to be used at their intended pressure and temperature ratings. **DO NOT OPERATE VALVES BEYOND THE PARAMETERS SPECIFIED ON THE TAGS, NAMEPLATES, OR PRODUCT STENCILING.**
2. User is responsible for the installation of safety device on the line where the valves are to be installed to prevent over pressurization.
3. Industry standard safety practices must be strictly adhered to while working with the products. Only properly qualified and trained personnel should perform any task or work on this product. Users of these products should contact MGM with any questions prior to installation and operation of the products.
4. Extra caution should be exercised during start-up and shut-down.
5. Products should be inspected and maintained periodically to avoid damage or injury.

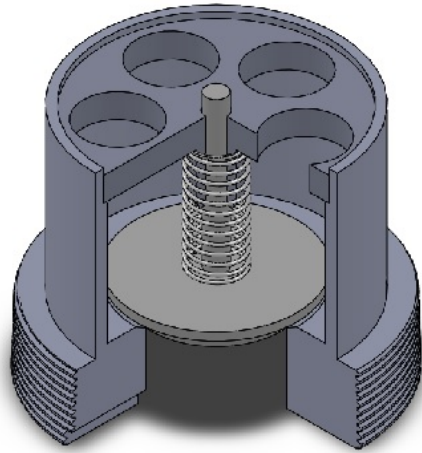

Figure 1: Valve Diagram

FUNCTION

MGM model 302 back pressure check valves (BPCVs) are spring loaded check valves. When properly sized and installed, they are designed to allow flow in one direction only. These valves are recommended for all inflowing lines when outward flow is never required. Back pressure check valves should be installed as close to the tank as possible, with the stem pointed inwardly toward the tank.

Please follow the installation directions below to ensure valve is in the proper orientation. The valve will only allow flow in one direction.

INSTALLATION

1. The MGM model 302 back pressure check valve is designed for use in threaded tank nozzles. Male pipe threads are provided on the bottom end of the valve.
2. All installations must be in accordance with NFPA Standards 58 and 59 as well as state, provincial and local regulations.
3. It is recommended that the valve be located such that there are at least 10 diameters of unrestricted line downstream of valve (i.e. no elbows, pumps, etc.).
4. Each valve will have an arrow stenciled on the outside of the valve body. Proper orientation of the valve will have the **arrow pointing in towards the tank.**
5. Please call MGM for technical support if you have any questions regarding installation.



OPERATION INSTRUCTIONS

1. Back pressure check valves are designed to allow flow in one direction only. The check mechanism is held in the closed position by a spring that stops flow in the reverse direction.
2. When pressure from flow in the permitted direction overcomes the force of the spring, the check mechanism opens. When flow stops or reverses, the check closes. The metal to metal seal allows slight leakage after closure.

MAINTENANCE INSTRUCTIONS

- No special maintenance is required on MGM BPCVs
- Valves do not have an elastomeric seat or seal that require periodic maintenance
- Valve inspection should be performed during the same intervals as other valve maintenance programs
- Items to inspect:
 - Damaged Seat
 - Broken Spring
 - Broken Poppet
 - Excessive corrosion

If any part of the valve is questionable please contact MGM for repair or replacement recommendations. **DO NOT TAMPER WITH DEVICE.** Any and all maintenance shall be performed by MGM.

TESTING INSTRUCTIONS

Testing the BPCV does not require flow through the valve. The valve should be tested by pushing the bottom of the poppet to its full open position. If after releasing the bottom of the poppet it automatically shuts, the valve is in satisfactory working condition. If the valve remains in the open position, contact MGM for further instructions.